

SOLAR SALTWORKS PRODUCTION PROCESS EVOLUTION - WETLAND FUNCTION

by Nicholas A. Korovessis

*Chemical Engineer M.Sc.
Technical Director, HELLENIC SALTWORKS S.A.
1, Asklipiou str, 10679 Athens, Greece*

Themistokles D. Lekkas

*Rector of the University of the Aegean
30, Voulgaroktonou str., 114 72 Athens, Greece*

ABSTRACTS

Solar saltworks are very well known plants, mainly because of their product. Salt is one of the world's best-known minerals and the chemical substance most related with the history of human civilization. Its significance for the creation of life itself on the planet and its importance as a commodity are paramount.

Nevertheless, the development of a unique saline ecosystem in parallel with the salt production process has not always been understood. The biological process that develops along with the increasing salinity gradient in the evaporating ponds and crystallisers of saltworks, produces excellent food for many kinds of birds, which for this reason rest, feed and breed in saltworks.

The basic steps in the evolution of solar salt production process are identified, where the final one corresponds to modern saltworks operation. It is shown that especially modern saltworks are not just salt production plants but they also function as integrated saline wetlands. Their ecological importance consists in the fact that they comprise the characteristics of both regular and hypersaline wetlands.

Modern saltworks are also compared with natural saline ecosystems, taking as an example the case of Kalloni Saltworks in Lesvos island and "Aliki" lake, located in the nearby island of Lemnos.

INTRODUCTION

Salt, the common name for the compound of sodium (Na^+) and chloride (Cl^-), is the first substance after water to have attracted humans' attention in their



Salt stockpile at Kitros Saltworks

evolution from wilderness to civilisation. Both its significance in the creation of life itself on the planet and its importance as a commodity are paramount.

It is common knowledge that life began in the oceans, where the first monocellular organisms were created. Although some creatures left their marine environment after a long evolutionary process, they continued being dependent on salt (Young 1977). Nowadays, we know that sodium chloride is the basic extracellular electrolyte of the human body and that the salinity levels of the environment where human foetuses develop are similar to those of the sea! Therefore, salt has remained a necessary element for the survival and proliferation of not only herbivorous animals, which take the necessary quantity of salt by licking the salty soil, but also for carnivorous ones, which ensure the necessary intake of salt from the blood of their prey.

The time when humans began engaging in farming activities and became settlers coincides with their search for salt, which is provided by nature in abundance. Salt along with water, cereals (bread) and the meat of domestic animals constituted the staple basis of human society in its infancy. Humans must have found salt where it can still be found, that is, in concave rocks of coastal areas or in lagoons where seawater gets trapped and deposits salt as it evaporates in the sun. At a certain point in their history, humans must have copied nature and produced salt on their own by evaporating seawater via either solar energy or ebullition.

Originally, salt was used to cater for the needs of human diet but later, it was discovered that it had significant food preserving properties. This particular property made salt one of the most important commodities for centuries. It is understood that in pre-classical Greece not knowing the use of salt was considered a

sign of barbarism. Many references to salt were made by Greek and Roman philosophers (Homer, Plato, Herodotus, Democritus, Aristotle, Strabo, Pliny, etc.), but this does not fall under the scope of the present paper. It is well known that the English word “salary”, comes from the Latin “salarium”, meaning the money Roman legionaries were paid to buy salt (Young 1977). The root of both words is the Latin sal (salt), which derives from the Greek words “ἕλξ” (sea) and “ἅλας” (salt). The initial letter *s* in the Latin word derives from the early Greek, whereby the words for salt and sea started with an *s* (sigma) too. Later, in ancient Greek, this *s* was dropped and was replaced by the breathing ‘.

The significance of salt as a commodity is only comparable to the importance of oil in our times. Although after the industrial revolution the use of salt as food preservative and its overall economic significance gradually began to decline, people’s needs in salt did not follow the same trend. On the contrary, the extensive use of sodium chloride in industry and in particular, its use as raw material



Coastal concavities and lakes where nature produces salt

in the chemical industry have increased dramatically salt consumption worldwide, with annual figures reaching 200 million tonnes nowadays. One third of this is produced in solar saltworks. About 20% of the international salt production is destined for human consumption, whereas 55% is used in the chemical industry and 15% is spread on roads to thaw ice or snow in winter.

SEAWATER COMPOSITION

Seawater constitutes the raw material for the production of salt in solar saltworks. It is well known that this raw material is inexhaustible, amounting to approximately 5×10^{16} tonnes.

It is worth noting that, the relative ratio of the various ions contained in seawater is almost independent from its overall salinity, it is practically the same on every coast of all open seas. However the overall salinity of seawater changes, as a result of the different evaporation rates for each sea or ocean.

The concentration of seawater through solar evaporation results in the successive crystallisation of the less soluble salts (CaCO_3 , CaSO_4) first, followed by NaCl and finally Magnesium salts. Saltworkers use the empirical Baume ($^\circ\text{Be}$) scale, to measure the concentration of brines. According to that scale the seawater concentration is 3.5°Be . The crystallisation of CaCO_3 begins at 4.6°Be and that of CaSO_4 at 13.2°Be . NaCl crystallises at 25.7°Be , followed by the more soluble Mg salts at 30°Be .

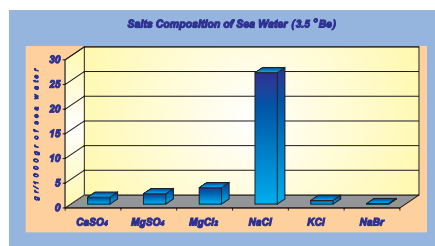
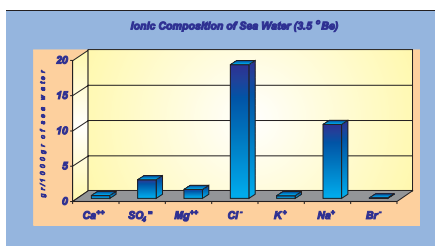

J. Usiglio, published the first scientific paper studying the fractional crystallisation of all salts contained in seawater through its gradual evaporation under controlled conditions, in 1849. It is a classic study, which inspired Vant Hoff in his phase rule studies (Baas-Backing 1931). Subsequent studies offered only a fragmentary approach to the issue. It was only in 1974 that G. Baseggio presented a comprehensive study of the composition of seawater and its concentration, in the 5th International Conference on Salt. The present paper has used data from the aforementioned study.

SOLAR SALT PRODUCTION PROCESS

Producing salt from seawater involves the selective recovery of pure NaCl , free of other soluble or non-soluble salts and other substances. To this end, an appropriate quantity of seawater is concentrated through natural evaporation, which leads to the fractional crystallisation of all salts contained; a process based on their varying solubility.

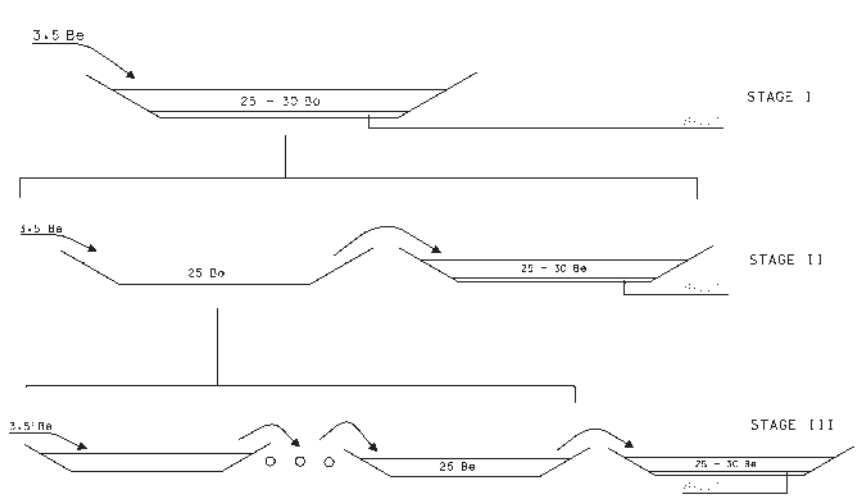

Figure 1. Basic stages in solar salt production process evolution

As already mentioned, originally, humans found salt in coastal concavities or in lagoons where seawater was trapped, evaporated in the sun and deposited its salt content. It can be deduced that, after a long period of observation and knowledge-building, humans eventually copied nature and began producing salt in quantities meeting their personal and social needs, thus moving away from nature's production rates. This is therefore, the initial stage and constitutes the first form of the solar sea salt production process hereby described.

This method has certain disadvantages since the salt produced contains all the ingredients of seawater and it is very difficult to produce relatively pure NaCl (in fact, it requires great experience). Moreover, this method of salt production is a batch process, with limited production rates.

The second step in the process of salt recovery from seawater was made with the division of the evaporation basin into two (figure 1). The first basin, usually called nurse pond, was used for the production of saturated (in NaCl) brine, which was fed into the second basin, usually called crystalliser.

Thus, it was made possible to:

- achieve continuous salt production (crystallisation) and to unbound the salt production rate,
- eliminate those seawater salts, with less solubility than NaCl (i.e. CaCO_3 and CaSO_4), since these crystallise in the first basin and remain there.

The third and most decisive step concerned the division of the nurse pond into several interconnected basins. With this design, seawater enters the first basin and, as it flows through the next ponds and evaporates in the sun, its concentration increases. Thus, by the time it reaches the last basin, which has now

become the nursing pond, it has a concentration of 25.7° Be, corresponding to the saturated brine in terms of NaCl.

This production method:

- ensures greater control over the concentrations and quantities of the brines fed through the system, thus resulting in the unobstructed production of much better quality salt,
- increases dramatically the quantity of the salt produced as the average brine concentration in the system of ponds decreases drastically - it is known that there is an inverse proportion between evaporation levels and concentration of brines,
- presupposes a system of evaporation ponds with increasing concentration (from 3.5 to 26° Be), which cover around 90% of the total area of the saltworks and create a complete, living ecosystem, as will be explained further in this paper. This production method is still used nowadays for the recovery of salt from seawater, although there have been improvements and variations, allowing for the production of some hundred to some million tonnes of salt, depending on the size of the area in use.

These three stages constitute the basic steps towards improving the saltmaking technology. Unfortunately, there are no data or information available confirming the time when the aforementioned production methods were first used, although it is certain that it has not been a uniform process throughout the world. The fact that in Greece, all stages in the evolution of saltmaking technology are still alive even nowadays is impressive. The saltworks on the island of Kythera, for instance, still produce salt in concave rocks by the sea. I was also told by a farmer in Mani (southern Peloponnese) that in his village, people use coastal salt-troughs to produce thick brines, which are then taken by pack animals to specially designed basins where salt is still produced nowadays. It is obvious that these still active saltworks, constitute the traditional saltworks of our country and their way of operation is the traditional method of salt production in Greece.

Already since the establishment of the Greek state, Greek saltworks had passed onto the third stage of the production process. A network of salt depots was already in place and the state traded in salt in cooperation with the saltworks scattered in various parts of the Greek territory of that time. According to what could be deduced from certain 19th century royal decrees, such as the decree of April 11, 1833, the output of Greek state saltworks was limited. The Spanish saltmaker J. Santoza, with whom the Greek state began collaborating in 1917, contributed significantly to the modernisation of Greek saltworks. In the ensuing years, the production of saltworks improved dramatically, thus meeting the country's needs in salt and allowing for its exportation to neighbouring countries.

MODERN SALTWORKS - WETLAND FUNCTION

Modern saltworks are semi-artificial coastal ecosystems, unique in terms of their architecture. Moreover, they have a special feature, which is highly valued



Evaporating pan dikes — Kalloni Saltworks



Flock of terns on a saltworks islet (Kalloni)

in our times: they combine their production process with the conservation of the environment. This is so because such process is not only environment-friendly, but also saltworks themselves constitute integrated ecosystems.

They consist of a system of shallow ponds (15-60 cm deep), connected mainly in series, and their natural bottom has the appropriate clay composition to ensure very low water permeability. Their operation principle is basically no different from the one described in the third stage of the previous chapter. The only differences that have occurred since the method was first applied, concern its optimisation as well as the means by which brine is transferred and salt is collected, resulting from subsequent technological progress.

According to this method, the ponds are divided into two basic groups. The first group, usually called evaporating ponds or ponds, is where seawater is concentrated up to saturation point in terms of NaCl (25.7° Be).

The second group, called crystallisers, consists of the basins where salt is crystallised and produced via further evaporation of the brine up to 28-29° Be. What basically elevates saltworks to ecosystems is the fact that for seawater to be concentrated up to the point of salt crystallisation, 90% of its water content has to evaporate, thus requiring a vast surface. For this reason, ponds take up approximately 90% of the saltworks area. Their bottom is totally natural without any intervention and the concentration of contained brine covers the whole range from 3.8° Be (almost seawater) to 25.7° Be, corresponding to the last pond which feeds the crystallisers continuously with



Washing and stockpiling of salt - Kalloni Saltworks



Avifauna of Kalloni Saltworks evaporating ponds



Salt harvesting — Kitros Saltworks

the required saturated brine (nurse). Crystallisers take up the remaining 10% of the area. These basins are specially designed and have their bottom levelled and concentrated, aiming to facilitate and optimise the collection of salt with machinery.

The first pond of the saltworks is fed with seawater (raw material) usually via pumping. As seawater flows from pond to pond, its concentration rises continuously through natural evaporation. The evaporation (concentration) of brine is achieved by exposure to solar radiation and with the help of the prevailing microclimate in the area, especially the winds, rainfall, air temperature and humidity and duration of sunshine. So an increasing salinity (concentration) gradient is created throughout the ponds of the saltworks with a simultaneous and continuous reduction of the volume of seawater, which initially entered the system of pans. This is the physicochemical process of salt production.

The evaporation of an open surface of water (or brine) is a complex phenomenon of simultaneous transfer of mass, energy and momentum and can be simu-

lated with the mathematical model (Pancharatnam 1972) given below:

$$h\rho_w C_{pw} \frac{dT_w}{dt} = \alpha R_N - \varepsilon\sigma(T_w + 460)^4 - h_G(T_w - T_a) - \lambda k_G(p^* - p_a) - h_L(T_w - T_{sg})$$

$$\frac{\partial T_g}{\partial t} = \mu_g \frac{\partial^2 T_g}{\partial x^2}$$

with boundary values: $x = 0, -h_L(T_w - T_{sg}) = \alpha_{sg} Q_g + K_g \left(\frac{\partial T_g}{\partial x} \right)_{x=0}$

$x = \infty, \frac{\partial T_g}{\partial x} = 0$

where:

$h_{G,L}$: heat transfer coefficients	Q_w : brine density
k_G : mass transfer coefficient	T_w : brine temperature
h : brine depth	T_a : air temperature
R_N : direct and indirect solar radiation	T_{sg} : ground temperature
α : refraction index	p_a : partial pressure of water in air
C_p : specific heat capacity	p^* : saturation vapor pressure of brine
K_g : ground thermal conductivity	μ : thermal diffusivity
λ : latent heat of vaporization	t : time

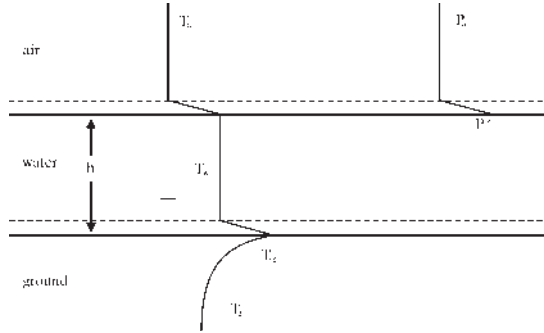

Figure 2. Pond model.

However, apart from the physicochemical process described above, a biological process develops in the evaporating and crystallising ponds, which is equally important to the production of salt. Surprisingly enough, despite rising salinity, life in the basins of the saltworks does not stop. Seawater organisms gradually disappear as they move from the initial pan to the hostile environment of the others. However, other organisms develop in their place and, as there is no competition, they proliferate. Such large populations are able to survive in areas with different concentration levels (that is, in different pans) because of their varying sensitivity to the ion composition of the medium they inhabit. Thus, in parallel with the physicochemical process, a chain of microorganisms is developed in the evaporating ponds system, constituting the biological process of the salt production process. Such a chain is similar to those of naturally saline or hypersaline coastal ecosystems.

The biological process of saltworks is a sensitive process and depends on:

- the prevailing conditions in the basins of the saltworks (temperature, depth and turbidity of brine),
- the rational control of the natural (physicochemical) process during salt production and,
- the overall design of the saltworks.

As can be seen on the very indicative diagram below (figure 3, J. Davis), the small crustacean *Artemia Salina*, also called brine shrimp, is the key organism in this biological chain.

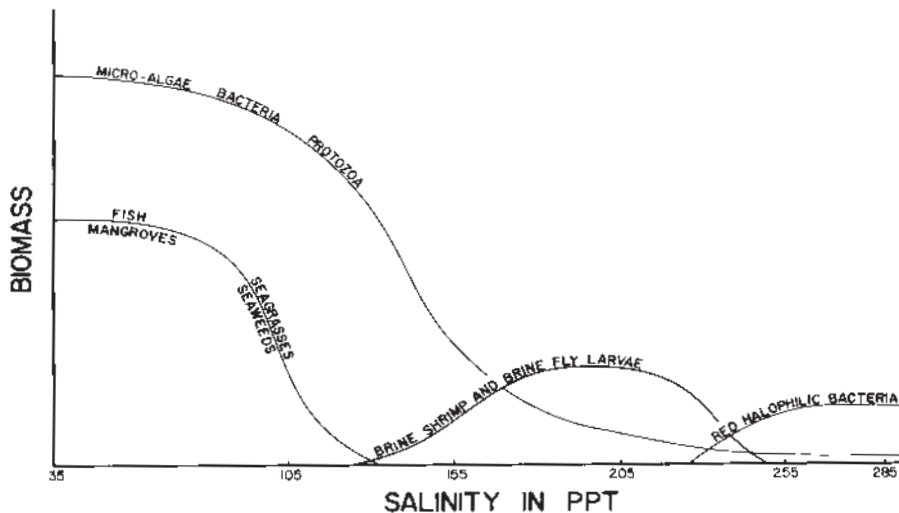

Figure 3. Biomass of main organisms in saltworks ponds and crystallisers.

It constitutes the link between the organisms living in low concentration pans and those of high concentration pans. Organisms developing in saltworks that operate efficiently constitute a biological system or ecosystem, which interacts with the physicochemical process and is vital to the production of salt. The first attempt to interrelate in detail the physicochemical and the biological process developed in solar salt production, is presented in figure 4 (J. Davis).

The biological system is in admirable harmony with the production process of the saltworks, in three ways:

- it produces the appropriate quantity of organic matter, which is a source of energy for the various organisms, and reduces the permeability of the bottom of the ponds, thus minimising brine losses, particularly at low concentrations,
- it colours red the brines in the crystallisers, thus maximising the evaporation rate, by maximising the rate of solar energy absorption and eliminating solar radiation reflection from the white saltbed. The red colour of the brines in the crystallisers is due to Halobacterium and to the monocellular seaweed *Dunaliella salina* and,

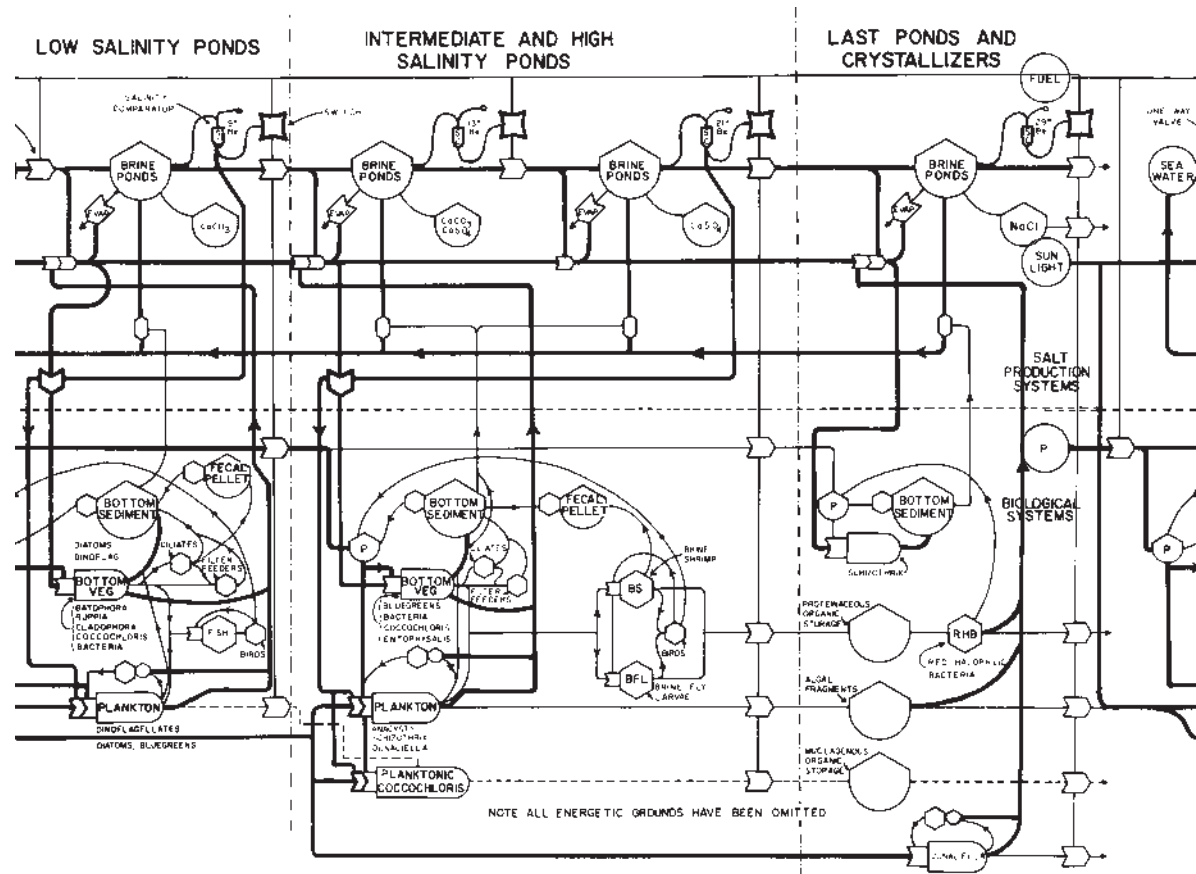

Figure 4. Interaction of physicochemical and biological process in solar saltworks.



Artemia adults and cysts in a Kalloni evaporating pond

- finally it creates and maintains the appropriate conditions in the evaporation ponds and the crystallisers, for the continuous and maximal production of high quality salt, which is characterised by clear, compact and mainly thick granules, low in Ca^{2+} (0.03-0.06%), Mg^{2+} (0.003-0.05%), SO_4^{2-} (0.10-1.2%) and admixtures of soil (0.01-0.02%).

When the biological system of saltworks is upset - due to either negligent operation and generally deficient design, or to the pollutants carried in the seawater, which is fed into the saltworks - an excessive quantity of organic matter is produced. Thus, the biological chain is altered and the saltworks become downgraded with the reduction of the surface of the ponds and increased viscosity of the brine resulting in the production of bad and sometimes potentially not marketable quality salt. Therefore, it is clear why the **optimal operation of modern saltworks is impossible without maintaining, at the same time, a healthy and stable ecosystem**. This was very difficult to achieve in traditional saltworks, the operation of which was fragmentary and the control of the brine flow negligent. We finally end up with the following surprising, for a production process, **paradox, that modern saltworks are better and more stable ecosystems than the traditional ones**.



Coloured brine in crystalliser



Aerial view of Kalloni Saltworks during its reconstruction

However, the ecological importance of the saltworks is mainly connected to its ornithological interest. Basic organisms of the biological system described above constitute excellent food for a large number of birds living in the saltworks for this matter. Certain species of birds, especially the Avocet, the Black-necked Grebe, the Kentish Plover etc., depend directly on the productivity of the saltworks, since their diet is exclusively based on *Artemia salina*. *Artemia* is also part of the diet of the beautiful flamingos and it is the main reason for the orange colour of their feathers.

On average, more than 100 species of birds have been observed in each of the Company's saltworks (188 in the saltworks Kitros in 1990), many of which have been identified as endangered species, or are protected by Greek, European Union or international conventions. It is worth noting that saltworks are totally free of pesticides or other chemical compounds used in farming.

Considering the case of Kalloni saltworks, located in the north Aegean Sea Island of Lesvos, which was recently redesigned and modernised, we can make the following remarks:

- there was a remarkable increase in bird species and population,
- Ornithologists reported a movement of many flamingos from lake "Alikí" of Lemnos island to Kalloni saltworks (Lemnos is another Aegean sea island located north of Lesvos),
- Flamingos built nests in Kalloni saltworks for the first time in Greece,
- Ecotourism is developed in the area, especially in April and May.

SALTWORKS vs NATURAL WETLANDS

The lake "Alik" of Lemnos is a natural coastal lake, covering an area of 6,300,000 m², where salt is produced naturally without any human intervention. Because of the hydrogeological conditions prevalent in the area, the lake is flooded with seawater in combination with autumn and winter rainfalls. With the influence of the local microclimate, which is highly conducive to evaporation, the trapped quantity of seawater constantly condenses until salt is finally produced. The crystallisation of salt usually starts in June and finishes in July. In early August the lake usually "dries up" of brine and the whole phenomenon repeats itself the following winter. In fact, throughout this natural process, a chain of microorganisms similar to the one described above develops, constituting the biological system of the lake.

If we compare the operation mode of the natural ecosystem of "Alik" lake of Lemnos with that of modern saltworks, the only substantial difference is the fact



Avocets - Kalloni Saltworks



Waterbirds - Kalloni Saltworks



Black-winged Stilt - Kalloni Saltworks

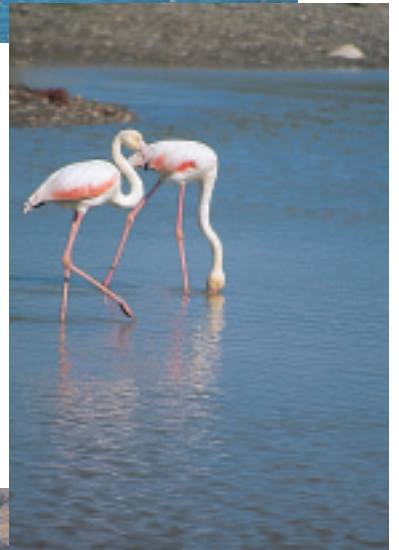

Phoenicopterus ruber (flamingoes) - Kalloni Saltworks



Pelicans on a Kalloni Saltworks dike

that, in the first case the salinity gradient develops with respect to time, whereas in saltworks with respect to area. This means that what takes place throughout the year in the lake of Lemnos in terms of the physicochemical and biological processes, in the case of saltworks it occurs at any moment without a drying up period. Obviously this difference is in favour of the saltworks, which constitute a stable ecosystem throughout the whole year.



Nests and chicks – Kalloni Saltworks

Furthermore saltworks are areas free of chemical contaminants, fertilisers etc., used by agriculture, whereas natural wetlands are not. This is true because, in the case of saltworks, all the effluents of the surrounding area go through their surrounding protective channel directly to the sea.

Another difference, which is derived from what has already been explained, is that saltworks consist from more than one, interconnected ponds (lakes). This intervention results in two more advantages (assuming properly designed saltworks):

- birds can use the constructed dikes for nesting
- small birds find more shallow waters, comparing with the case of one big lake, where they can feed.

It is worth mentioning the surprising announcement of ornithologists at the Samos Conference, who observed a movement of many flamingos from Aliko lake to Kalloni saltworks. This movement is most probably related with the nesting of flamingos in Kalloni.

I believe that ecologists should realise that the modernization, viability and expansion of saltworks secures the existence of those really valuable saline ecosystems. Finally, I would like to conclude with the phrase that salt-workers in my country use to succinctly characterise their work: **“we conserve the environment by producing salt”**.



Nesting of flamingoes in Kalloni Saltworks



People use to bathe in concentrated brine to soothe the skin and bone diseases.

REFERENCES

- Baas-Becking, L.G.M. 1931. Historical Notes on Salt and Salt-Manufacture. *Scientific Monthly*, pp. 434-446.
- Young, G. 1977. Salt, the Essence of Life. *National Geographic*, pp. 381-401.
- Hocquet, J.C., Hocquet J. 1987. The history of a food product: salt in Europe. A bibliographic review. *Food and Foodways*. Vol. 1, pp. 425-447.
- Usiglio J., 1849. *Annales Chem. P.* 27:92-107 as cited in Clarke F. W., 1924. The data of geochemistry. *U.S. Geol. Survey Bull.*, pp. 770:219.
- Baseggio G. 1974. The composition of seawater and its concentrates. *Proc. 4th Int. Symp. Salt Vol. 2*, pp. 351-358. Northern Ohio Geological Society, Inc., Cleveland, Ohio.
- Pancharatnam, S. 1972. Transient Behavior of a Solar Pond and Prediction of Evaporation Rates. *Ind. Eng. Chem. Process Dev. Develop.*, Vol. 11, No 2, pp. 287-292.
- Garrett, D.E. 1966(a-b). Factors in design of solar plants. Part 1. Pond layout and construction. Part 2. Optimum operation of solar ponds. *Proc. 2nd Int. Symp. Salt Vol. 2*, pp. 168-187. Northern Ohio Geological Society, Inc., Cleveland, Ohio.
- McArthur, J.N. 1980. An approach to process and quality control relevant to solar salt-field operations in northwest of western Australia. *Proc. 5th Int. Symp. Salt Vol. 1*. Northern Ohio Geological Society, Inc., Cleveland, Ohio.
- Davis, J.S. 1974. Importance of microorganisms in solar salt production. *Proc. 4th Int. Symp. Salt Vol. 2*, pp. 369-372. Northern Ohio Geological Society, Inc., Cleveland, Ohio.
- Davis, J.S. 1980. Biological management of solar saltworks. *Proc. 5th Int. Symp. Salt Vol. 1*, pp. 265-268. Northern Ohio Geological Society, Inc., Cleveland, Ohio.
- Davis, J.S. 1993. Biological management for problem solving and biological concepts for a new generation solar saltworks. *Proc. 7th Int. Symp. Salt Vol. 1*, pp. 611-616. Elsevier Science Publishers B.V., Amsterdam.

- Sammy, N. 1983. Biological systems in north - western Australian solar salt fields. Proc. 6th Int. Symp. Salt Vol. 1, pp. 207-215. The Salt Institute, Alexandria, Virginia.
- Tackaert, W., Sorgeloos, P. 1993. The use of brine shrimp artemia in biological management of solar saltworks. Proc. 7th Int. Symp. Salt Vol. 1, pp. 611-616. Elsevier Science Publishers B.V., Amsterdam.
- Kaufmann, D. W. 1960. Sodium chloride. The production and properties of salt and brine. Monograph series no. 145. Hafner Publishing Company, Inc.
- Petanidou, T., Korovessis, N. 1994. Conserving nature we produce salt throughout Greece. Hellenic Saltworks S.A., 34 pages.